

# 41/s (9E41) MODION®

ION PUMP—DIODE

[www.modionvacuum.com](http://www.modionvacuum.com)

## MODION® 9E4L

- Please read and understand these instructions prior to installation and use of this ion pump.
- For Further Support Please call or email J.B. Anderson & Son, Inc.
- 724.523.9610
- [support@modionvacuum.com](mailto:support@modionvacuum.com)
- 115 Railroad Street  
Irwin, PA 15642

The 9E4L MODION® is a compact, rugged ion pump. This instruction manual covers our commercial pump. For custom pumps and power supplies, please contact J.B. Anderson & Son, Inc.



### Table of Contents:

Overview	1
Description	2
Application and Installation	3
Theory of Operation	6
Troubleshooting, Maintenance, & Ser-	7
Specifications	8
Figures	9
Warranty	12
Company & Contact Info	13



## 1.0 DESCRIPTION OF MODION® PUMP AND GAUGE

The 4l/s MODION® ion pump is a small, lightweight, portable ion pump unit. The pump can be connected to our HVPS-C remote power supply (sold separately). Using our HVPS-C, a 0-5VDC analog signal continuously monitors the level of vacuum within the pump.

The MODION® Pump/Gauge may be operated from a switchable wall adapter for fixed operation, or by battery or customer supplied regulated 12V for portable operation:

A. The standard Model 110/220VAC switchable wall adapter.

B. Operation from batteries or customer supplied 12Vdc to provide backup or portable operation. This mode can permit complete portability during processing, storage and shipping of a user's vacuum device.

Note: using the MODION® with a non-J.B.A. power supply voids the 1 year limited warranty

The MODION® is readily disassembled to permit UHV bake out of the pump unit at temperatures up to 300C. For ultra-high vacuum applications, bake out is essential to insure pump cleanliness and performance. High energy rare earth magnets greatly reduce the MODION's® size, weight and stray magnetic field. **THESE MAGNETS MUST BE REMOVED PRIOR TO ANY BAKE OUT ABOVE 100C.**

Please read the instructions to familiarize yourself with the other features of the MODION® system and its care and use.

## 2.0 INSTALLATION AND USE

### 2.1 APPLICATION

The J.B. Anderson & Son, Inc. MODION® when used in its pumping mode, is intended for use as an appendage pump for UHV systems applications requiring continuous pumping of self-outgassing products. The MODION® requires an oil-free, clean high vacuum to reach its starting pressure of approximately  $1 \times 10^{-4}$  Torr. (A turbo-molecular pump, cryogenic pump, auxiliary ion pump, or a well-trapped oil diffusion pump is sufficient for this purpose.) Bake out of any high vacuum system is recommended to reduce outgassing and to achieve rated pumping speeds.

J.B. Anderson & Son, Inc. MODION® ion pumps are available with a variety of tubulation sizes of flanges. If the tubulation is to be brazed/flared to the user equipment, care must be taken to purge it full with dry nitrogen to keep the unit clean and free of oxides. **DO NOT HYDROGEN BRAZE—THIS PROCESS WILL DESTROY THE CATHODE'S PUMPING ABILITY.** Any mating connections should also be prepared before the shipping flange is removed from the MODION® pump. The MODION® may be mounted in any convenient location and orientation. Please read and understand all instructions prior to installing or using the MODION®.

## 2.2 Installation

(Pump)

The ion pump is packaged and shipped assembled (with magnets and yoke). The pump unit is pumped down during bake-out, and remains in high vacuum condition during shipment. Each MODION® should remain sealed until the time of installation on the customer's device to preserve maximum cleanliness of the internal cathodes. Each unit undergoes inspection and testing during each phase of manufacturing, and is helium leak tested prior to shipment.



### HAZARDOUS VOLTAGE CAN CAUSE SEVERE INJURY OR DEATH

#### **BEFORE INSTALLING OR REMOVING CONNECTOR**

- READ AND UNDERSTAND THIS ENTIRE MANUAL
- TURN POWER OFF
- BE SURE ENTIRE SYSTEM IS GROUNDED PRIOR TO INTRODUCING POWER

#### **Connecting Pump**

1. Verify there is no power to the HVPS. (Do not plug wall adapter in)
2. Connect the pump side of cable connector to the ion pump.
3. Connect the controller side of the cable to the HVPS.
4. **Check to make sure the entire system is grounded prior to introducing power.**
5. Connect wall adapter power cable to HVPS
6. Plug in wall adapter to operate.

#### **Disconnecting Pump**

1. When disconnecting pump, disconnect power to HVPS **prior** to removing any other cable.
2. Wait thirty (30) seconds before disconnecting cable. Failure to wait 30 seconds may result in shock due to capacitors not being fully discharged.
3. Disconnect cable from the HVPS power supply first, followed by the ion pump.

When installing flanged units, always use clean, new copper gaskets of a type recommended by the flange manufacturer. Handle gaskets only at the edges. Use washer under flange nuts and apply molybdenum disulfide lubricant to all bolt threads. Use a torque wrench to tighten bolts evenly to 8 ft/lbs.

In the interest of good vacuum practice and to realize potential pumping speeds, keep tubulation as short as possible. If your MODION® unit has a mesh screen inside the conflat-style flange, do not remove this screen.

**IMPORTANT: TO INSURE ELECTRICAL SAFETY, THE MODION® BODY AND POWER SUPPLY MUST BE AT LOCAL ELECTRICAL GROUND POTENTIAL. WHEN MOUNTED TO A METAL VACUUM SYSTEM, MAKE SURE THE MOUNTING SURFACES ARE TRULY GROUNDED. WHEN MOUNTING TO A GLASS OR OTHER NON-CONDUCTING VACUUM SYSTEM, A SEPARATE GROUNDED LEAD MUST BE CONNECTED SECURELY TO THE MODION® AND HVPS.**

### 2.3 BAKEOUT.

1. Follow disconnecting instructions in section 2.2
2. Make certain that no input power is connected to the MODION®.
3. Remove JBA quick disconnect cable according to disconnecting instructions in section 2.2.
4. Remove magnet return yokes and magnets from pump. (Handle the magnets with care; they will be chipped or broken by sudden attraction to each other or to iron objects.)

Note: Ion pumps should be under vacuum of at least  $10^{-4}$  Torr during bakeout.

During bake out of the pump unit, monitor pump body temperature to avoid over heating.

### 2.4 ASSEMBLY OF MODION® AFTER BAKEOUT

Assembly will be the reverse of disassembly instructions.

After bakeout and cool down, re-install the magnets and magnet yokes onto the pump unit, observing magnet polarity and minimizing gaps where the yokes overlap each other.

Note: make certain all mounting screws are secure to insure proper grounding of the entire system—power supply and pump included. **If proper grounding is not present, a shock hazard may exist.**

### 2.5 HVPS POWER SUPPLY UNIT CHARACTERISTICS (Sold Separately)

The MODION® electronics are specifically designed to limit the current to the pump unit to safe values at operating pressures above  $10^{-5}$  Torr, and also limit current drain during off-scale pressure conditions. This modular power supply unit may be operated at ambient temperatures from 0 to 60C.

### 3.0 OTHER OPERATING MODES

#### 3.1 BATTERY OPERATION

The MODION® system may be operated from a 12 volt battery for both backup or portable use. Separate battery inputs are provided to enable powering of the HVPS (sold separately)

Connections for battery operation are made to the pins of the HVPS (sold separately) as shown in Figure 1.

#### 3.2 ANALOG OUTPUT SIGNAL

A 0-5 volt analog output signal is available from the modular power supply. This signal can be used to drive remote indicators or chart recorders and generate calibration, resolution, or a permanent record of system pressure. Connections for this signal are made to the pins on the HVPS as shown in Figure 1.

(Figure 2) in this manual may be used to relate analog output voltage to system pressure.

#### 3.4 HUMID & HIGH VACUUM ENVIRONMENTS

The MODION® system itself may be operated successfully in a humid or vacuum ambient environment without threat of high voltage breakdown at critical pressures, if the volume around the HV connection is carefully packed with clean silicone high voltage grease before the pump/JBA quick disconnect cable (sold separately) are assembled together. Make certain air voids are not left in this insulating packing by applying sufficient material to fill the cavity.

#### 4.0 THEORY OF OPERATION

The MODION® ion pump utilizes the Penning discharge to ionize the residual gas molecules inside the pump. The magnetic field confines the discharge to a small volume within the pump, and increases the efficiency of pumping by greatly increasing the number of collisions with electrons generated by the ionization process. Thus, a relatively dense cloud of spiraling electrons is formed within the discharge to ionize gas molecules more efficiently. The process is self-regulating so that the discharge does not go from Townsend to ARC. The ions formed are accelerated to the cathodes (titanium) where they impact with sufficient energy to become entrapped. This process, called “sputtering”, creates a continuously renewed surface of pure titanium molecules, which accomplish the active pumping.

A clean titanium surface has a high chemical attraction (affinity for almost all chemically active gases (H<sub>2</sub>, N<sub>2</sub>, O<sub>2</sub>, etc.) When an active gas molecule strikes the fresh titanium surface, it is bound to that surface by strong chemical bonds. These gases are in effect, “pumped” by the titanium surface. The sputtering process also effectively buries gas molecules under layers of fresh titanium as the process continues over a long period of time.

The Inert gases (He, Ar, Kr, Xe) have little affinity for titanium, and these gases are held weakly to the surface by ionic bonds. The probability of these gas molecules adhering to the titanium surface is low, and the binding forces are much weaker than for other gases.

The “pumping” action of a titanium film surface can also be affected by ion bombardment at the cathodes. High energy ions striking the cathode not only sputter fresh titanium, but will release a small number of previously pumped molecules as well. For this reason one often observes an initial rise in pressure when the pump is first activated.

For the inert gases, a re-emission rate is more pronounced (particularly for argon which constitutes nearly 1% of the earth’s atmosphere by volume). The repetitive cycling from atmosphere to high vacuum tends to produce an argon-enriched background which must be removed to produce higher vacuum in the pump and in the user’s volume. Best pumping performance results from prolonged bake out at high temperatures (350C if possible) using an auxiliary UHV pumping means. The MODION® pump is well suited for repetitive bake out at temperatures up to 300C.

Note: Be sure to remove power supply, adapters, magnets, and return yokes prior to bake out.

## 5.0 TROUBLESHOOTING, MAINTENANCE, AND SERVICE

### CAUTION: HIGH VOLTAGE

*DISCONNECT ALL INPUT POWER BEFORE SERVICING, THEN WAIT 30 SECONDS FOR POWER SUPPLY CAPACITORS TO DISCHARGE.*

*All troubleshooting, service, and inspection should be performed by qualified individuals only.*

#### Troubleshooting:

**PROBLEM:** Failure to start at pressures known to be within the normal operating range of the MODION® ion pump.

Perform the following checks to determine the cause:

1. Check to make sure the power supply "POWER ON" lamp is lit. If this lamp is not lit, check the wall adapter power supply by substitution or by observing 12Vdc across pins 6 & 7 of this unit's cable connector.
2. Tap pump body gently with small non-magnetic metal tool. Dislocating of surface gas molecules will cause initiation of discharge.
3. Check to see if magnet yokes are installed with no air gaps at yoke joints, and with proper magnet polarity. (north and south should be "looking" at one another).
4. Inspect the pumps anode insulator (power supply removed). Measure insulation resistance with a high impedance ohmmeter capable of measuring resistances greater than 100 megohms. If resistance is below 10 megohms, there is leakage across the anode insulator. Wipe ceramic clean and dry, and retest.

**PROBLEM:** Monitor voltage behaves erratically.

1. Disconnect input power and then remove power supply from pump unit. Check for presence of dirt or dust inside the pump connector end of the cable, and clean as required.
2. Replace the power supply onto the pump unit and operate the MODION® system. If readings are still erratic, remove the magnets from the pump unit. If the display or analog output does not decrease, leakage across the anode insulator is indicated. Clean the insulator and recheck.

If these simple troubleshooting measures do not solve the apparent problem, please contact J.B. Anderson & Son, Inc. at [support@modionvacuum.com](mailto:support@modionvacuum.com). Please include a description of your observations.

## MAINTENANCE AND SERVICING

Because the MODION® pump power supply is encapsulated, all servicing on this unit must be done by the manufacturer.

The pump unit requires little or no maintenance. Approximate life is 20,000 hours when operated at  $10^{-6}$  Torr or lower pressures.

Whenever the pump unit is temporarily removed from the vacuum system, it should be stored in a clean, dry vacuum. It is important that the following points be followed before placing the unit in service again (flange mounted units).

1. Inspect the UHV mounting flange for nicks, scratches, and other defects along with the knife edge seal.
2. Inspect and clean the mouth of the flange with appropriate solvent to remove debris, oil, deposits, and other foreign material.
3. Make sure all power supply to pump fasteners are present and tight to avoid a possible shock hazard.

## 6.0 SPECIFICATIONS

1. Pump Unit Applied Voltage ————— +3500 VDC typical  
 Maximum Bake Out Temp ————— 300C when protected against  
 atmospheric oxidation of seals  
 Mass ————— 431gm
  
2. Modular Power Supply  
 Normal Input Voltage (Pin 3) ————— +12Vdc  
 Ground ————— (Pin 7)  
 Input Current ————— 800mA max (see note 1)  
 Output Voltage to Pump ————— +3500VDC +/- 20%  
 Case and Pin 7 ————— (Return) At Ground Potential  
 Operating Temperature Range ————— 0C to 60C

Note 1: Input current varies over pressure range; ex.200 mA at high pressure; less mA at lowest pressure.



**FIGURE 1**  
**HVPS PINOUT (Sold Separately)**

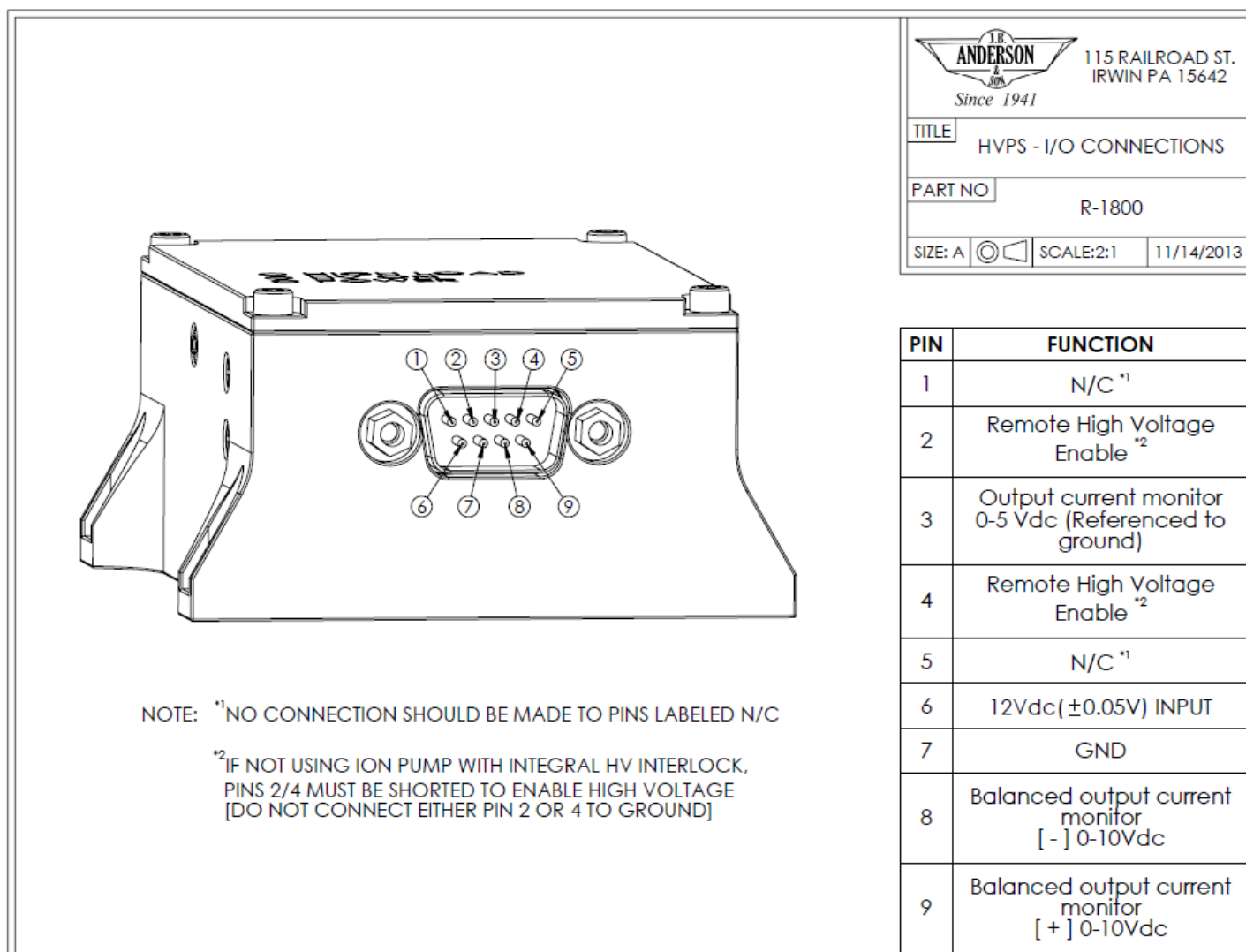

**FIGURE 2**  
**VOLTAGE VS. PRESSURE**

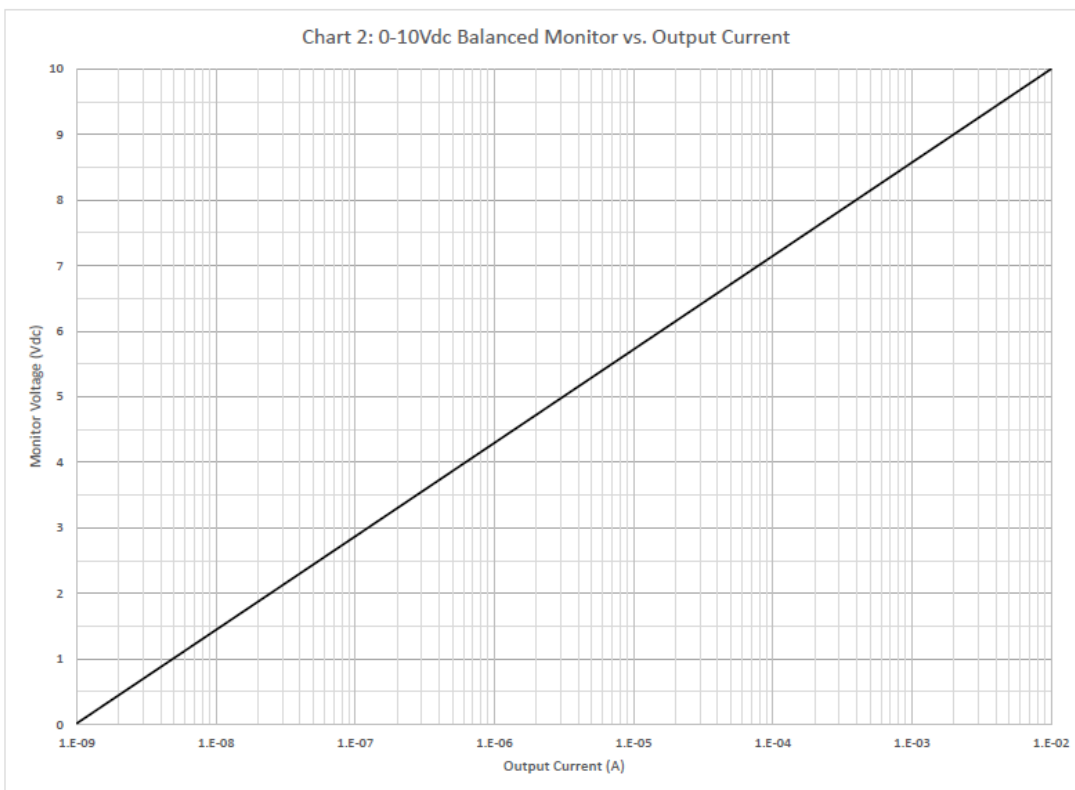
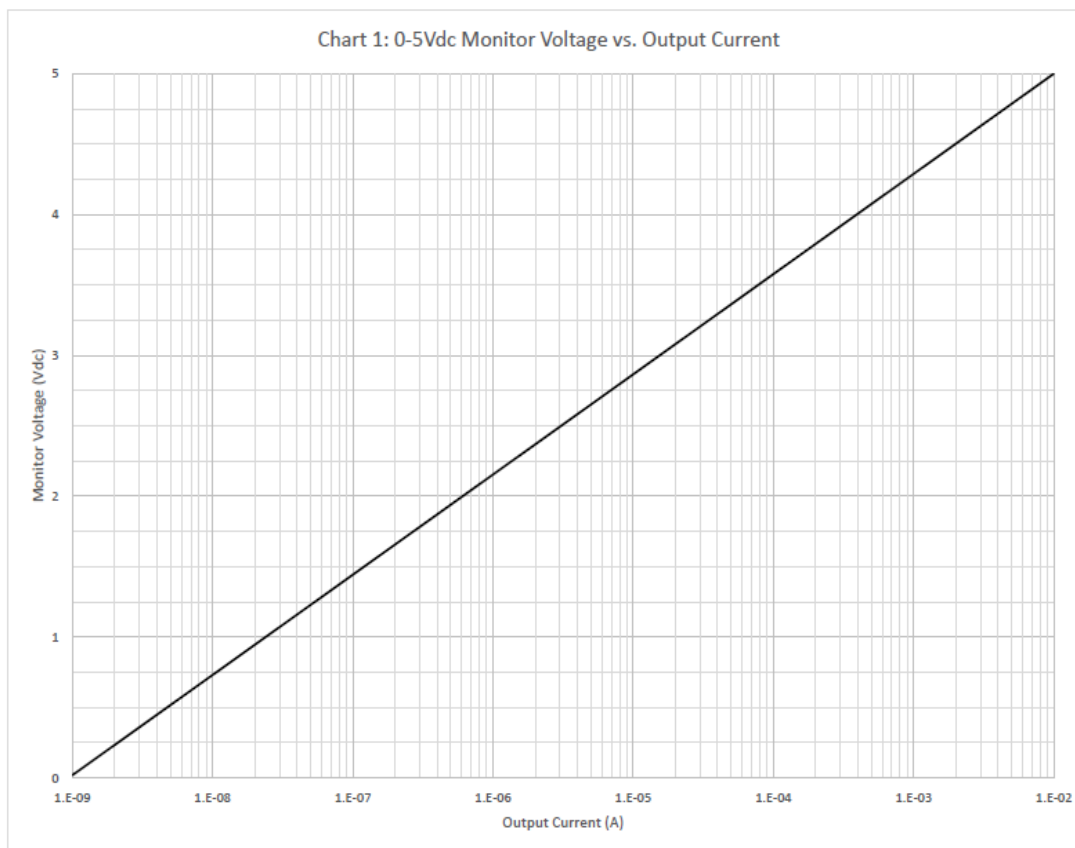

**FIGURE 3**  
**9E4I CONNECTED TO HVPS**



**FIGURE 4**  
**9E4I DIMENSIONS**

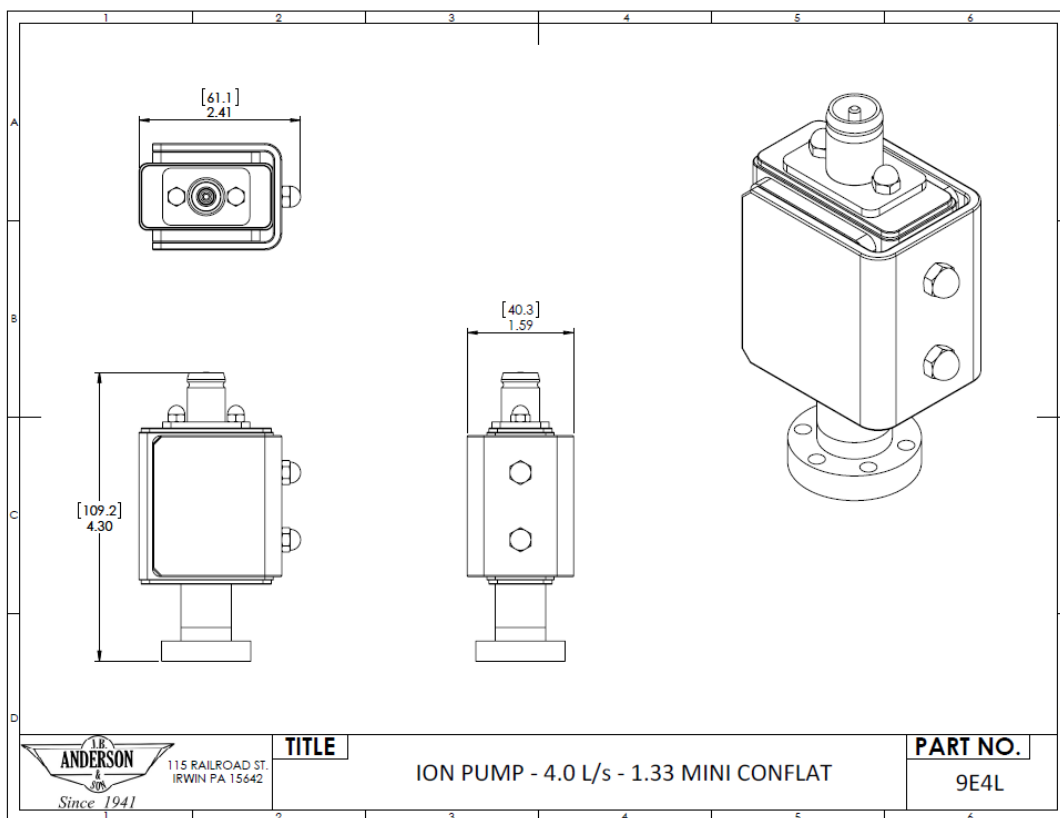

## Warranty Information

---

J.B. Anderson & Son, Inc. warrants all commercial MODION® systems to be free from defects in materials and workmanship for a period of twelve (12) months from date of shipment to customer when used in accordance with the accompanying instructions. All obligations of J.B. Anderson & Son, Inc. under this warranty shall cease in the event of abuse, alteration, misuse, improper installation or neglect of equipment. Reasonable care must be used to avoid hazards. J.B. Anderson & Son, Inc. expressly disclaims responsibility for loss or damage caused by use of the MODION® other than in accordance with proper operating procedures and conditions.

J.B. Anderson & Son, Inc.'s obligation under this warranty is limited to repair or replacement of the MODION®, at J.B. Anderson & Son, Inc.'s option. In no event shall J.B. Anderson & Son, Inc. be liable for any special, indirect, incidental or consequential damages.

J.B. Anderson & Son, Inc. makes no warranty of merchantability or fitness for any purpose, and no other warranty, oral or written, express or implied, except as specifically set forth in this limited warranty. No J.B. Anderson & Son, Inc. representative or distributor has any authority of power to alter or extend this limited warranty.

If the customer believes that a defect covered by this limited warranty exists, the customer must return the MODION® to J.B. Anderson & Son, Inc., postage prepaid, along with a description of the problem and proof of purchase, and contact information.



*Since 1941*

*J.B. Anderson & Son, Inc.*

115 Railroad Street  
Irwin, PA 15642

Phone: 724.523.9610

E-mail: [support@modionvacuum.com](mailto:support@modionvacuum.com)

*J.B. Anderson & Son, Inc. has been providing innovative manufacturing solutions since 1941. We manufacture commercial and custom MODION® ion pumps, power supplies, and TVC thermal vacuum chambers. In addition to our vacuum product lines, JBA is a full service manufacturing and design company, producing machined and welded parts, and assemblies to customer specification.*